

# DPS

The SSV Dual Pump System

---

## A Full Range of Product Features

The DPS series of 316L stainless steel vertical multi-stage pumps from G&L has been designed to provide reliable high pressure boosting to serve the needs of Commercial, OEM and HVAC customers.

1. The DPS (Dual Pump System) consists of two vertical multistage pumps from our SSV series specially designed so that they can be connected in series. The discharge of the first pump sends liquid directly to the suction of the second. This results in pressures which are approximately double those possible with a standard SSV.
2. The two pumps are supplied separately, and a kit is provided to connect them together, and to the system piping. Complete directions are included.
3. The first pump is a standard SSV with victaulic connections or flanges in 316L stainless steel. The second pump is a special design which uses a reverse internal stack to reduce pressure at the seal. The motors on the smaller sizes turn counterclockwise on this second pump. Higher flow units utilize the standard opposing impeller design.

## Typical Applications

- Reverse osmosis systems
- Industrial wash systems
- Drinking water production
- Pharmaceutical production
- Deionized and demineralized water treatment plants
- Filtering systems
- Treatment for chemically aggressive liquids
- Desalinization plants

## Specifications

- Flows to 340 gpm (72 cu. M/hr)
- Heads to 1320 feet (450 M)
- Maximum working pressure 575 psi (40 bar)
- Maximum static pressure 360 psi (25 bar)
- Liquid temperature range: 5 to 140°F (-15 to 60°C)
- Motors: single or three phase open or fan cooled.
- Connections: 1SV and 2SV – 1¼" victaulic, 3SV and 4SV – 2" victaulic, 5SV and 6SV – 2½". 300# ANSI drilled, raised face flanges.



**Flow Charts for DPS Models**

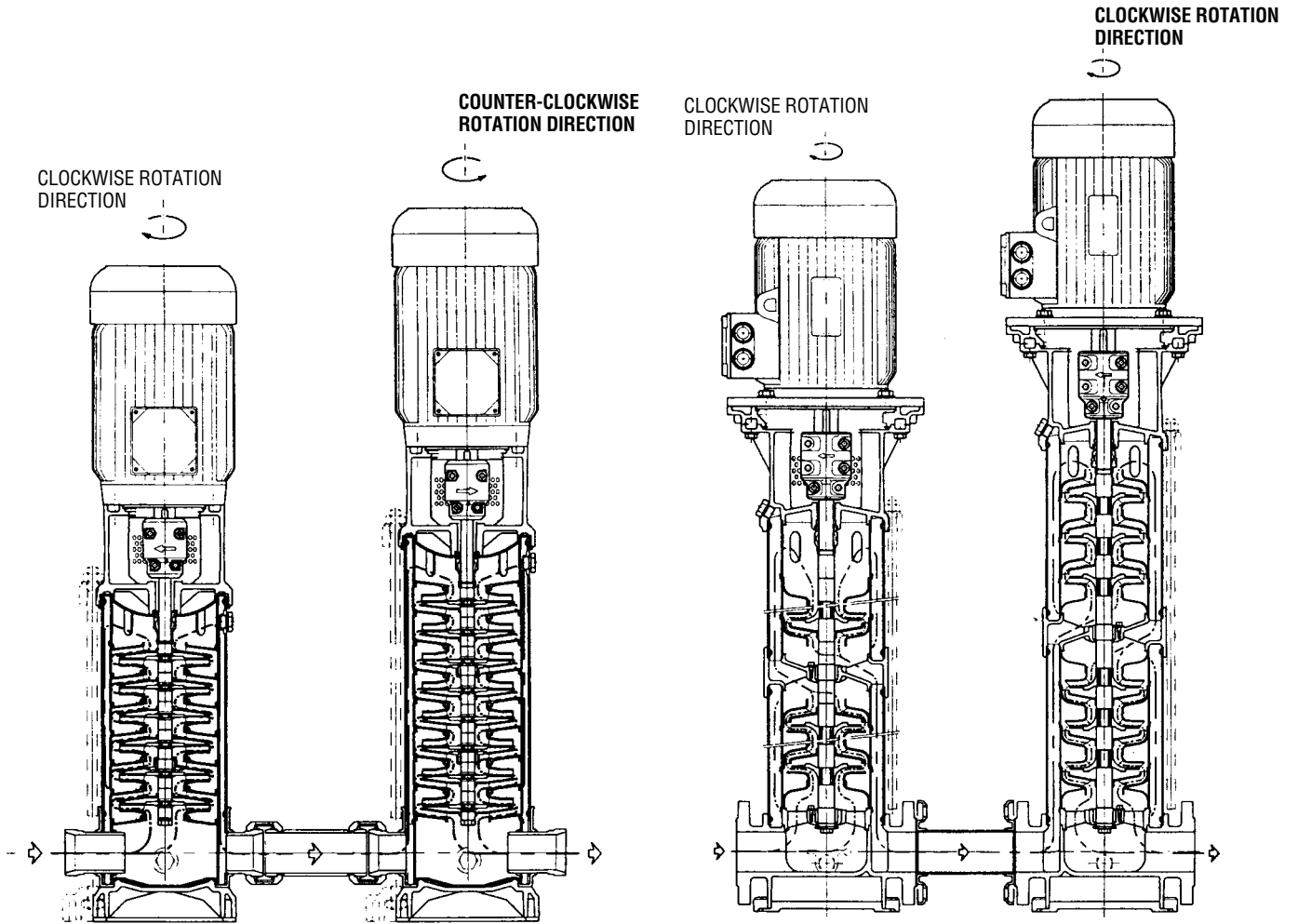

**Series 1SV, 2SV, 3SV and 4SV**

**Series 5SV and 6SV**

# DPS Range Curves

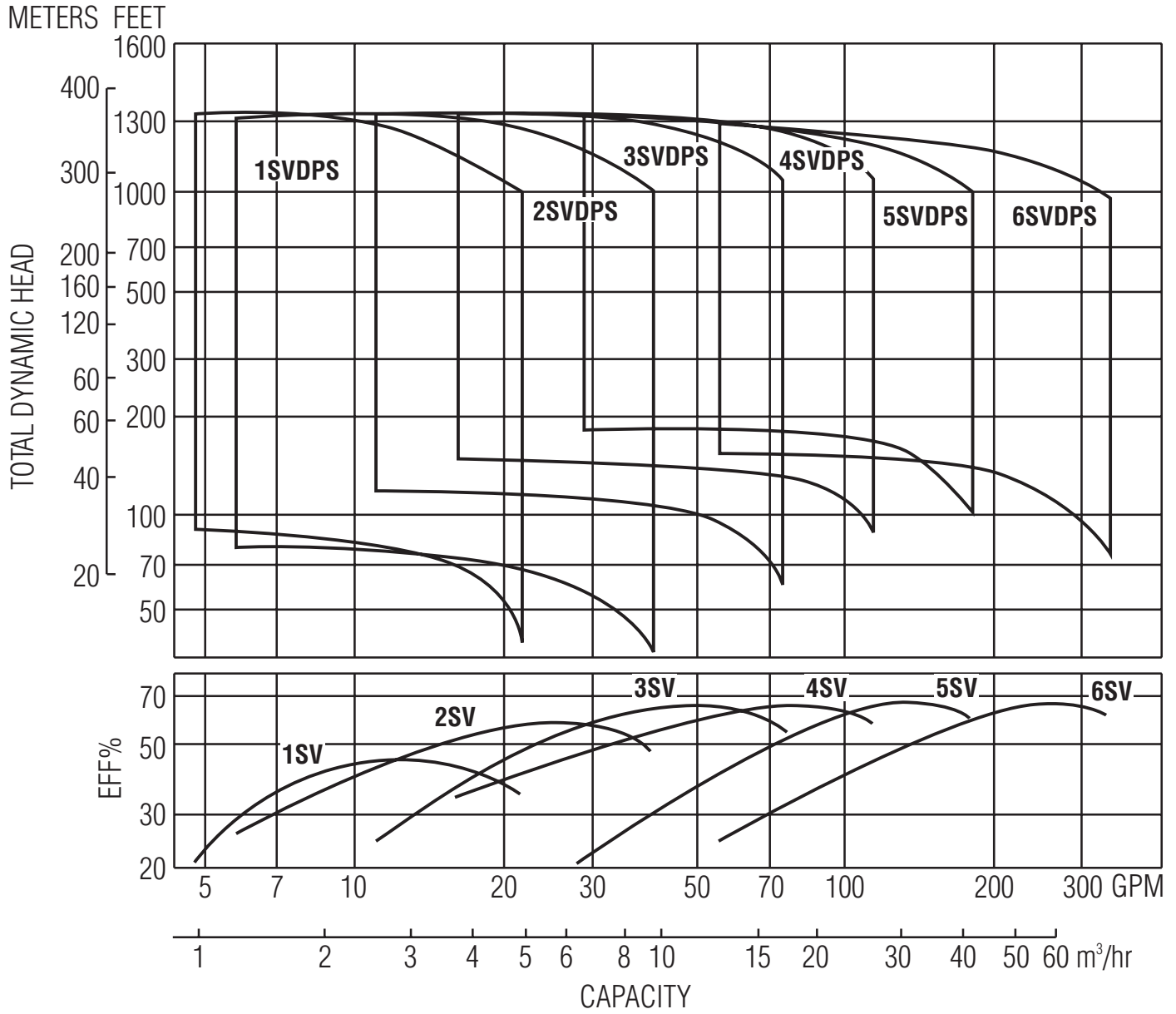

## DPS Product Line Numbering System

The various versions of the DPS line are identified by a product code number on the pump label. This number is also the catalog number for the pump. The meaning of each digit in the product code number is shown below.

**Note:** Not all combinations are possible. Consult your G&L Pumps distributor.

### Example Product Code

2 SV D 1 D 2 8 0 DPS

**Options:** DPS = Second pump designator  
VIC = Victaulic connections (**1SVD – 4SVD only**), required for first pump  
SP = Special flange (**6SVD only**), required for first pump

#### Mechanical Seal Options:

Code No.	Rotary	Stationary	Elastomer	Where Offered
0	Carbon	Silicon Carbide	Viton	Standard
4	Silicon Carbide		Viton	Optional on all units
6	High Temp. Carbon	Silicon Carbide	EPR	

#### Number of Stages:

B = 2 D = 4 F = 6 H = 8 K = 10 M = 12 P = 14 R = 16 V = 20 Z = 24  
C = 3 E = 5 G = 7 J = 9 L = 11 N = 13 Q = 15 T = 18 X = 22

#### Driver:

1 = 1 PH, ODP 3 = 575V, ODP 6 = 575V, TEFC 8 = 575V, XP  
2 = 3 PH, ODP 5 = 3 PH, TEFC 7 = 3 PH, XP 9 = 3 PH, TEFC with premium efficiency

#### HP Rating:

C = 1/2 E = 1 G = 2 J = 5 L = 10 N = 20 Q = 30 S = 50  
D = 3/4 F = 1 1/2 H = 3 K = 7 1/2 M = 15 P = 25 R = 40

#### Hertz/RPM:

1 = 60 Hz, 3500 RPM 5 = 60 Hz, 3500 RPM, 220-380 V, D.O.L.  
3 = 60 Hz, 3500 RPM, 380 V 6 = 60 Hz, 3500 RPM, 380 V, Y-DELTA

#### Material and Suction/Discharge:

D = 316L stainless steel, in-line ANSI flange or victaulic

#### Product Line:

Stainless steel vertical

#### Nominal Flow:

1 = 15 GPM 2 = 28 GPM 3 = 55 GPM  
4 = 86 GPM 5 = 145 GPM 6 = 290 GPM

## Victaulic Connections for 1SV, 2SV, 3SV and 4SV DPS Systems

- Pumps using this option are shipped with victaulic fitted suction and discharge connections. The connecting coupling and pipe end adapters may be ordered separately.
- Dimensions are in inches (mm).

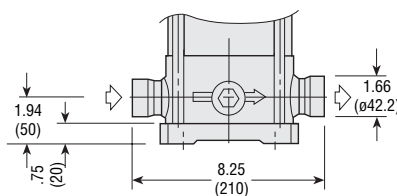

Dimensions of **1SV and 2SV** with victaulic connections

**1/4" Victaulic connection**

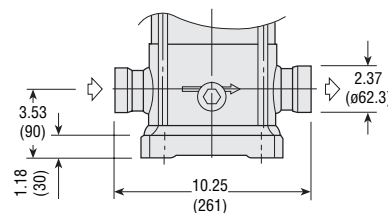

Dimensions of **3SV and 4SV** with victaulic connections

**2" Victaulic connection**

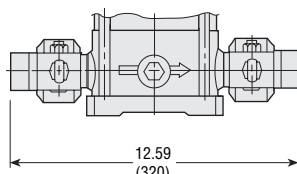

Dimensions of **1SV and 2SV** with couplings and pipe adapters

**1/4" x 1 1/2" NPT male thread**

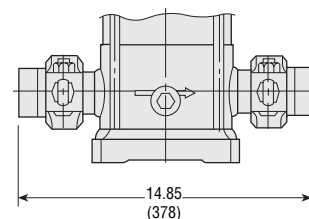

Dimensions of **3SV and 4SV** with couplings and pipe adapters

**2" x 1 1/2" NPT male thread**

## Base Model: 1SVDPS General Pump Description

Construction: 316L stainless steel  
 Capacities: 3–22 gallons per minute (1.1–5 m<sup>3</sup>/hr)  
 Heads: 420–1350 feet TDH (130–400 meters)  
 Staging: SSV Pump #1 = 2 – 11  
 DPS Pump #2 = 16  
 Minimum flow: 3 GPM

Component	Materials
Pump body	316L SS
Casing O-rings	Viton
Tie-rods and nuts	Zinc-coated steel
Pump shaft	316L SS
Pump casing	316L SS
Top seal housing	316L SS
Inner bowls	316L SS
Diffusers	316L SS
Impellers	316L SS
Impeller O-rings	Viton
Shaft spacers	316L SS
Shaft bushing	Ceramic
Shaft sleeve	Tungsten carbide
Seal spring and retainer clip	316L SS

  

Mechanical seal				
Code No.	Rotary	Stationary	Elastomers	Where Found
0	Carbon	Silicon Carbide	Viton	Stan. on all units
4	Silicon Carbide	Silicon Carbide	Viton	Optional
6	High Temp Carbon	Silicon Carbide	EPR	

Priming and drain plugs	316L SS
NEMA motor adapter	Cast iron
Coupling guards	304 SS
Motor shaft coupling	Cast aluminum
Pump base	Cast aluminum

## 1SVDPS Performance Curves

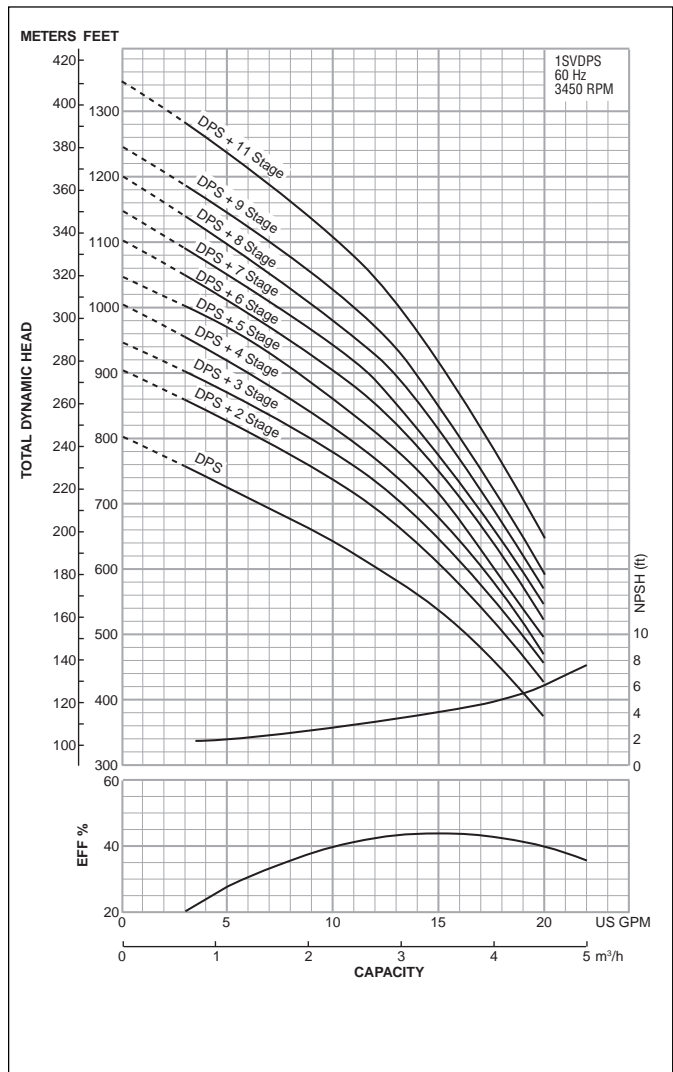

## 1SVDPS Motors

Standard motors supplied by Goulds are NEMA standard TC frame motors open drip proof, or totally enclosed fan cooled enclosures. 60 Hz, 3500 RPM, single phase ½ and 3 HP (115/208-230 V), 5 HP (208-230 V) and three phase (208–230/460 V). 1SV horsepower from ½ to 3, DPS horsepower is 5. For other motor options, contact the factory. Above motors are 1.25 S.F. for ½, ¾ and 1 HP. 1.15 S.F. for 1½–5 HP.

# 1SVDPS Dimensions and Weights

(All dimensions are in inches, weights are total unit weight.)

## 1SVD Series

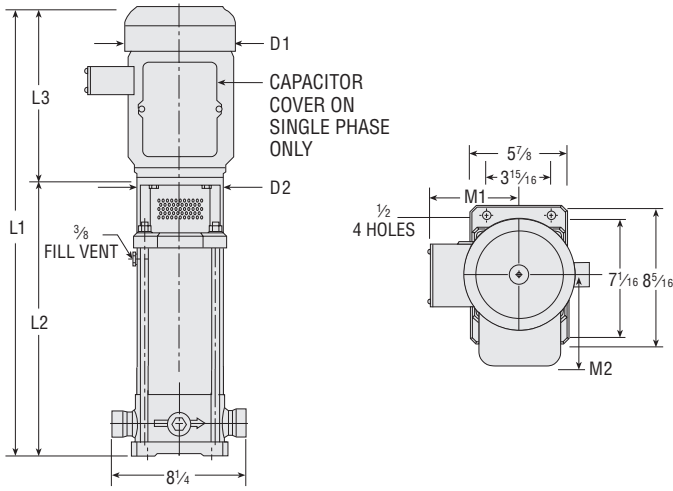

Pump	Stage	Motor		Dimensions (max.)						Wt. (lbs.)		
		Frame	HP	L1	L2	L3	M1	M2	D1	D2	ODP	TEFC
1	2	56C	1/2	21 1/8	12 11/16	9 3/16	4 3/8	4 15/16	5 11/16	6 3/4	45	45
				22		9 9/16	4 1/2	5 1/8			50	
	3	56C	3/4	23 7/16	13 3/8	9 13/16	4 3/8	4 15/16	5 11/16	6 3/4	50	50
				23 3/16		9 15/16	4 1/2	5 1/8			55	
	4	56C	1	25 1/4	14 5/8	10 3/8	4 3/8	4 15/16	5 11/16	6 3/4	55	65
				25 13/16		11 3/16	5 1/4	5 9/16			65	
	5	56C	1 1/2	26 7/8	15 5/8	11 1/4	5 1/4	5 5/8	6 5/8	6 3/4	65	70
				26 13/16		11 3/16		5 5/8			70	
	6	56C	2	27 1/8	16 1/8	11 1/4	5 1/4	5 5/8	6 5/8	6 3/4	70	80
				28 11/16		12 1/16		5 9/16			80	
	7	56C	2	28 13/16	17 1/16	11 1/4	5 1/4	5 5/8	6 5/8	6 3/4	70	80
29 3/8				12 1/16		5 9/16		80				
8	56C	3	30 3/4	18 9/16	12 3/16	5 1/4	5 5/8	6 5/8	6 3/4	80	105	
			30 5/8		12 1/16		5 9/16			105		
9	56C	3	31 3/4	19 9/16	12 3/16	5 1/4	5 5/8	6 5/8	6 3/4	80	105	
			31 5/8		12 1/16		5 9/16			105		
11	56C	3	33 11/16	21 1/2	12 3/16	5 1/4	5 5/8	6 5/8	6 3/4	85	110	
			33 3/16		12 1/16		5 9/16			110		
2	16	184TC	5	38 1/16	26 7/16	12	5 7/8	7 1/16	7 7/8	11 1/16	115	125
				41 1/2		15 1/16		125				

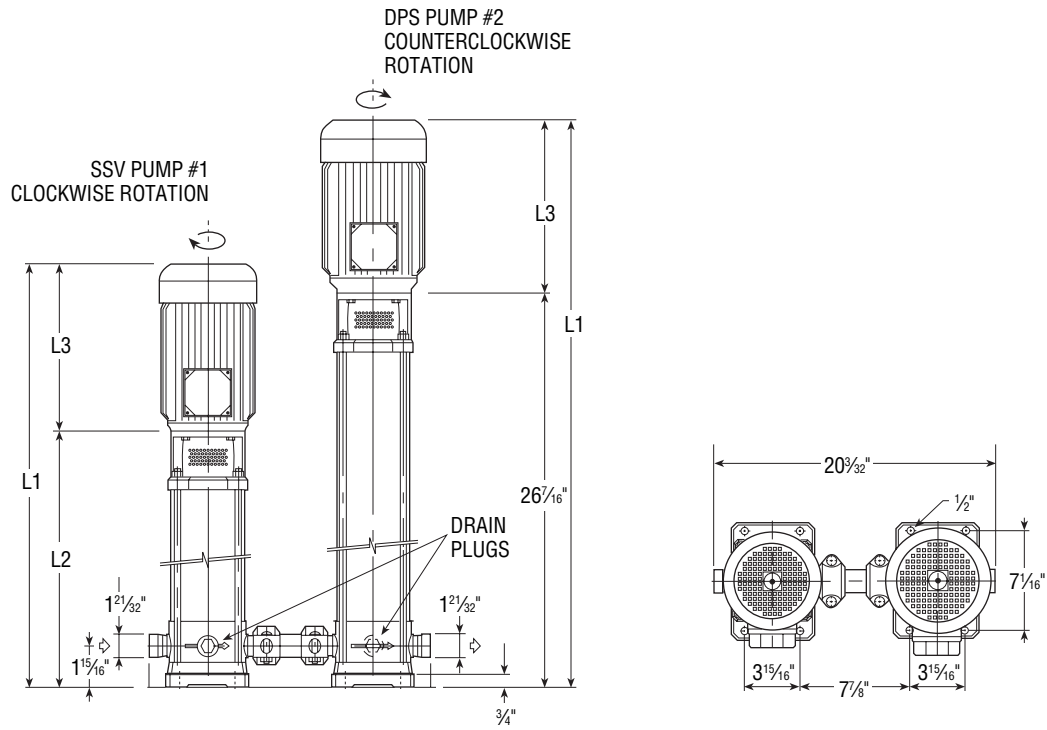

**Base Model: 2SVDPS**  
**General Pump Description**

**2SVDPS Performance Curves**

Construction: 316L stainless steel  
 Capacities: 6–40 gallons per minute (2.2–9 m<sup>3</sup>/hr)  
 Heads: 280–1350 feet TDH (85–400 meters)  
 Staging: SSV Pump #1 = 2 – 15  
 DPS Pump #2 = 15  
 Minimum flow: 6 GPM

Component	Materials
Pump body	316L SS
Casing O-rings	Viton
Tie-rods and nuts	Zinc-coated steel
Pump shaft	316L SS
Pump casing	316L SS
Top seal housing	316L SS
Inner bowls	316L SS
Diffusers	316L SS
Impellers	316L SS
Impeller O-rings	Viton
Shaft spacers	316L SS
Shaft bushing	Ceramic
Shaft sleeve	Tungsten carbide
Seal spring and retainer clip	316L SS

Mechanical seal				
Code No.	Rotary	Stationary	Elastomers	Where Found
0	Carbon	Silicon Carbide	Viton	Stan. on all units
4	Silicon Carbide	Silicon Carbide	Viton	Optional
6	High Temp Carbon	Silicon Carbide	EPR	

Priming and drain plugs	316L SS
NEMA motor adapter	Cast iron
Coupling guards	316L SS
Motor shaft coupling	Cast aluminum
Pump base	Cast aluminum

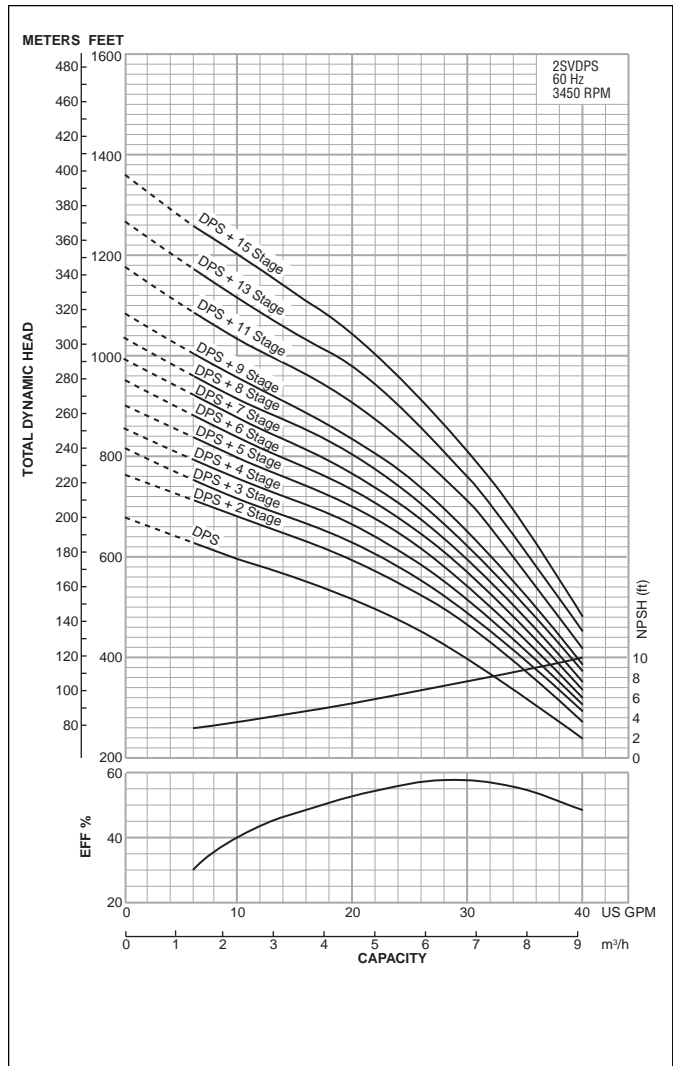

**2SV Motors**

Standard motors supplied by Goulds are NEMA standard TC frame motors open drip proof, or totally enclosed fan cooled enclosures. 60 Hz, 3500 RPM, single phase ½ to 3 HP (115-208/230 V), 5 HP (208-230 V) and three phase (208-230/460 V). 2SV horsepowers from ½ to 5. DPS horsepower is 5. For other motor options, contact the factory. Above motors are 1.25 S.F. for ½, ¾ and 1 HP. 1.15 S.F. for 1½ to 5 HP.

# 2SVDPS Dimensions and Weights

(All dimensions are in inches, weights are total unit weight.)

## 2SVD Series

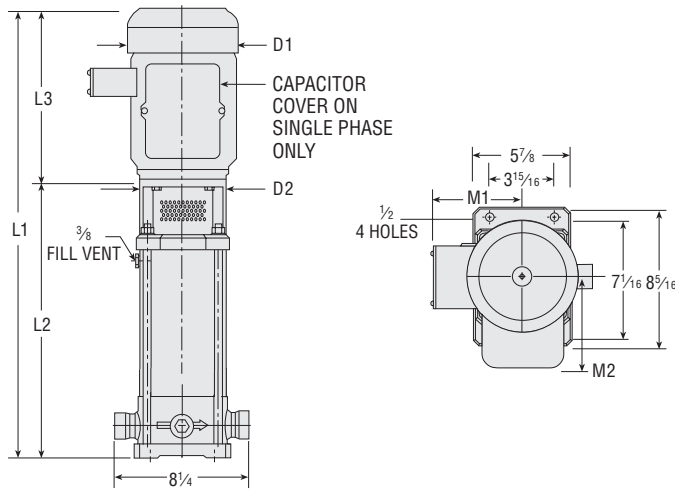

Pump	Stage	Motor		Dimensions (max.)							Wt. (lbs.)	
		Frame	HP	L1	L2	L3	M1	M2	D1	D2	ODP	TEFC
1	2	56C	3/4	22 1/2	12 11/16	9 13/16	4 3/8	4 13/16	5 11/16	6 3/4	45	
				22 5/8		9 15/16	4 1/2	5 1/8			50	
	3	56C	1	24 1/4	13 3/8	10 5/8	4 3/8	4 15/16	5 11/16	6 3/4	55	
				24 13/16		11 3/16	5 1/4	5 9/16			65	
	4	56C	1 1/2	25 7/8	14 5/8	11 1/4	5 1/4	5 5/8	6 5/8	6 3/4	65	
				25 13/16		11 3/16		5 9/16			65	
	5	56C	2	26 7/8	15 5/8	11 1/4	5 1/4	5 5/8	6 5/8	6 3/4	70	
				27 11/16		12 1/16		5 9/16			75	
	6	56C	2	27 7/8	16 5/8	11 1/4	5 1/4	5 5/8	6 5/8	6 3/4	70	
				28 11/16		12 1/16		5 9/16			80	
	7	56C	3	29 3/4	17 9/16	12 3/16	5 1/4	5 5/8	6 5/8	6 3/4	80	
				29 5/8		12 1/16		5 9/16			100	
	8	56C	3	30 3/4	18 1/16	12 3/16	5 1/4	5 5/8	6 5/8	6 3/4	80	
30 5/8				12 1/16		5 9/16		105				
9	56C	3	31 3/4	19 9/16	12 3/16	5 1/4	5 5/8	6 5/8	6 3/4	80		
			31 5/8		12 1/16		5 9/16			105		
11	184TC	5	33 1/2	21 1/2	12	5 7/8	7 1/16	7 7/8	11 19/16	110		
			36 7/16		15 1/16		7 1/16			120		
13	184TC	5	35 1/2	23 1/2	12	5 7/8	7 1/16	7 7/8	11 19/16	110		
			38 7/16		15 1/16		7 1/16			120		
1 & 2	15	184TC	5	37 1/16	25 7/16	12	5 7/8	7 1/16	7 7/8	11 19/16	110	
				40 1/2		15 1/16		7 1/16			125	

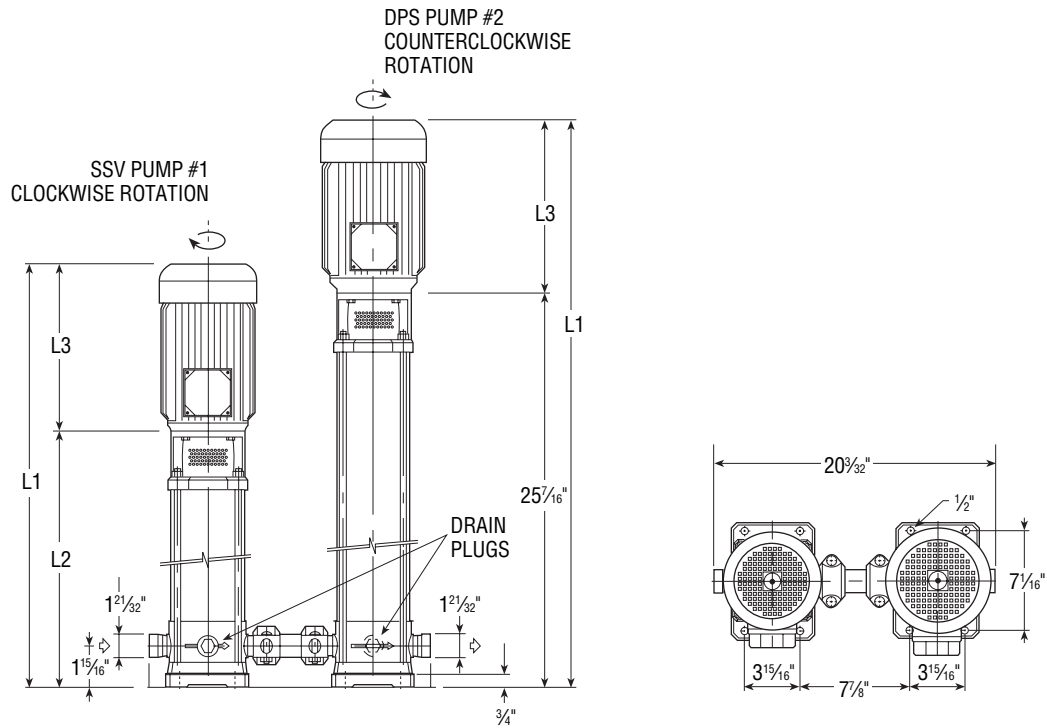

**Base Model: 3SVDPS**  
**General Pump Description**

**3SVDPS Performance Curves**

Construction: 316L stainless steel  
 Capacities: 11–75 gallons per minute (4.5–17 m<sup>3</sup>/hr)  
 Heads: 460–1320 feet TDH (140–400 meters)  
 Staging: SSV Pump #1 = 2 – 8  
 DPS Pump #2 = 13  
 Minimum flow: 11 GPM

Component	Materials
Pump body	316L SS
Casing O-rings	Viton
Tie-rods and nuts	Zinc-coated steel
Pump shaft	316L SS
Pump casing	316L SS
Top seal housing	316L SS
Inner bowls	316L SS
Diffusers	316L SS
Impellers	316L SS
Impeller O-rings	Viton
Shaft spacers	316L SS
Shaft bushing	Ceramic
Shaft sleeve	Tungsten carbide
Seal spring and retainer clip	316L SS

Mechanical seal				
Code No.	Rotary	Stationary	Elastomers	Where Found
0	Carbon	Silicon Carbide	Viton	Stan. on all units
4	Silicon Carbide	Silicon Carbide	Viton	Optional
6	High Temp Carbon	Silicon Carbide	EPR	

Priming and drain plug	316L SS
NEMA motor adapter	Cast iron
Coupling guards	316L SS
Motor shaft coupling	Cast aluminum below 5 HP and cast iron 5 HP and above
Pump base	Cast aluminum

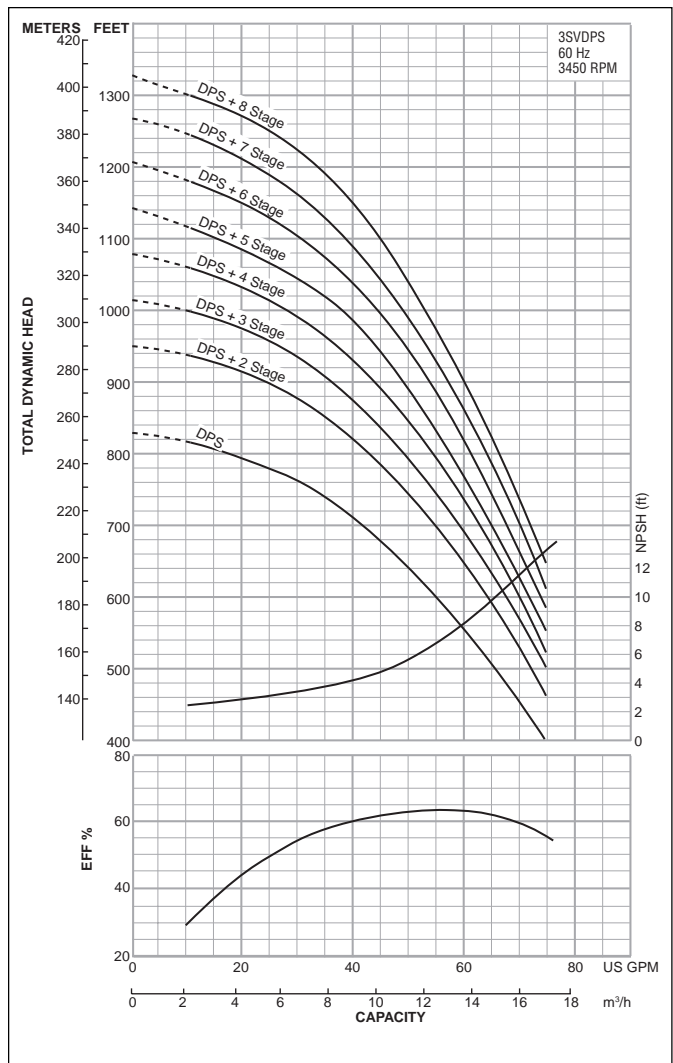

**3SV Motors**

Standard motors supplied by Goulds are NEMA standard TC frame motors open drip proof, or totally enclosed fan cooled enclosures. 60 Hz, 3500 RPM, single phase 2 to 3 HP (115/208-230 V) 5 HP (208-230 V) and three phase 2 to 10 HP (208-230/460 V). 15 HP (230/460 V) 3 SV horsepowers from 2 to 7½, DPS horsepower is 15. For other motor options, contact the factory. Above motors are 1.15 S.F.

# 3SVDPS Dimensions and Weights

(All dimensions are in inches, weights are total unit weight.)

## 3SVD Series

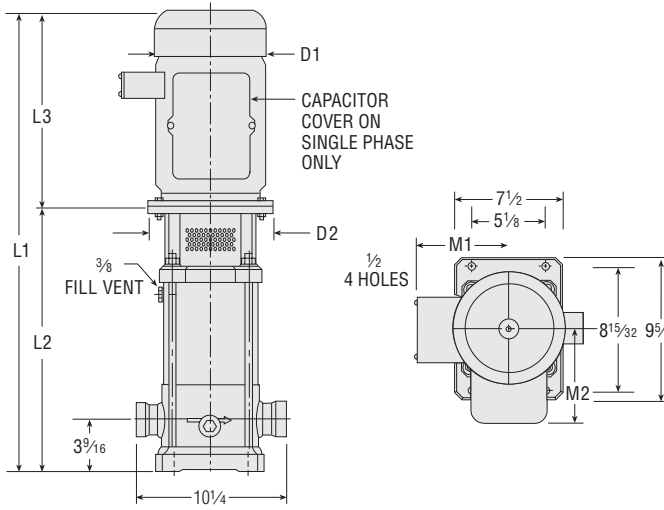

Pump	Stage	Motor		Dimensions (max.)							Wt. (lbs.)	
		Frame	HP	L1	L2	L3	M1	M2	D1	D2	ODP	TEFC
1	2	56C	2	27	15 3/4	11 1/4	5 1/4	5 5/8	6 5/8	6 3/4	75	85
			27 13/16	12 1/16		5 9/16						
	3	56C	3	29 7/16	17 1/4	12 3/16	5 1/4	5 5/8	6 5/8	6 3/4	85	110
			29 9/16	12 1/16		5 9/16						
	4	184TC	5	30 3/4	18 3/4	12	5 7/8	7 1/8	7 7/8	11 13/16	115	125
				33 13/16		15 1/16		7 1/8				
	5	184TC	5	32 1/4	20 1/4	12	5 7/8	7 1/8	7 7/8	11 13/16	115	130
	35 5/16			15 1/16		7 1/8						
6 & 7	184TC	7 1/2	35 1/4	23 1/4	12	5 7/8	-	7 7/8	11 13/16	125	135	
			38 5/16		15 1/16		7 7/8					
8	184TC	7 1/2	36 1/16	24 1/16	12	5 7/8	-	7 7/8	11 13/16	125	135	
			39 3/4		15 1/16		7 7/8					
2	13	215TC (ODP) 254TC (TEFC)	15	48 15/16	33 3/8	15 5/16	7 7/8	-	9 9/16	11 13/16	185	315
				53		19 5/8		8 15/16			11 1/2	

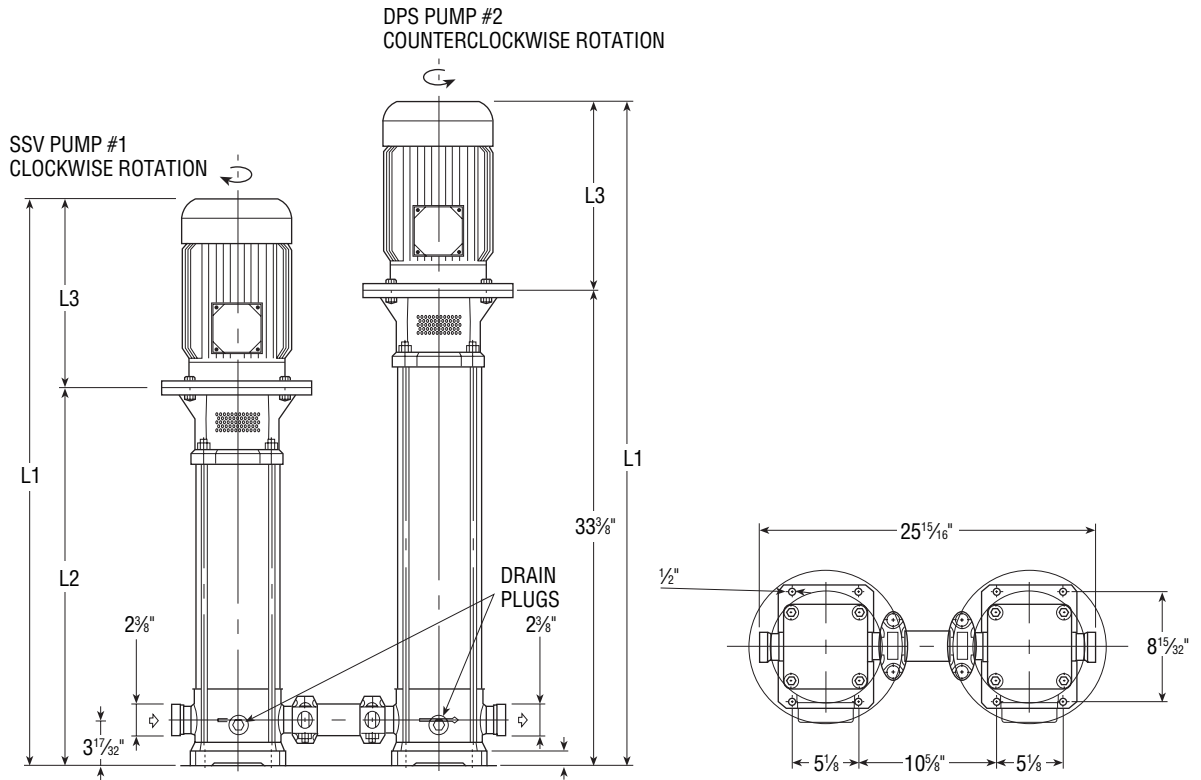

**Base Model: 4SVDPs**  
**General Pump Description**

**4SVDPs Performance Curves**

Construction: 316L stainless steel  
 Capacities: 17–110 gallons per minute (4–25 m<sup>3</sup>/hr)  
 Heads: 550–1320 feet TDH (167–400 meters)  
 Staging: SSV Pump #1 = 2 – 7  
 DPS Pump #2 = 10  
 Minimum flow: 17 GPM

Component	Materials
Pump body	316L SS
Casing O-rings	Viton
Tie-rods and nuts	Zinc-coated steel
Pump shaft	316L SS
Pump casing	316L SS
Top seal housing	316L SS
Inner bowls	316L SS
Diffusers	316L SS
Impellers	316L SS
Impeller O-rings	Viton
Shaft spacers	316L SS
Shaft bushing	Ceramic
Shaft sleeve	Tungsten carbide
Seal spring and retainer clip	316L SS

Mechanical seal				
Code No.	Rotary	Stationary	Elastomers	Where Found
0	Carbon	Silicon Carbide	Viton	Stan. on all units
4	Silicon Carbide	Silicon Carbide	Viton	Optional
6	High Temp Carbon	Silicon Carbide	EPR	

Priming and drain plug	316L SS
NEMA motor adapter	Cast iron
Coupling guards	316L SS
Motor shaft coupling	Cast iron
Pump base	Cast aluminum

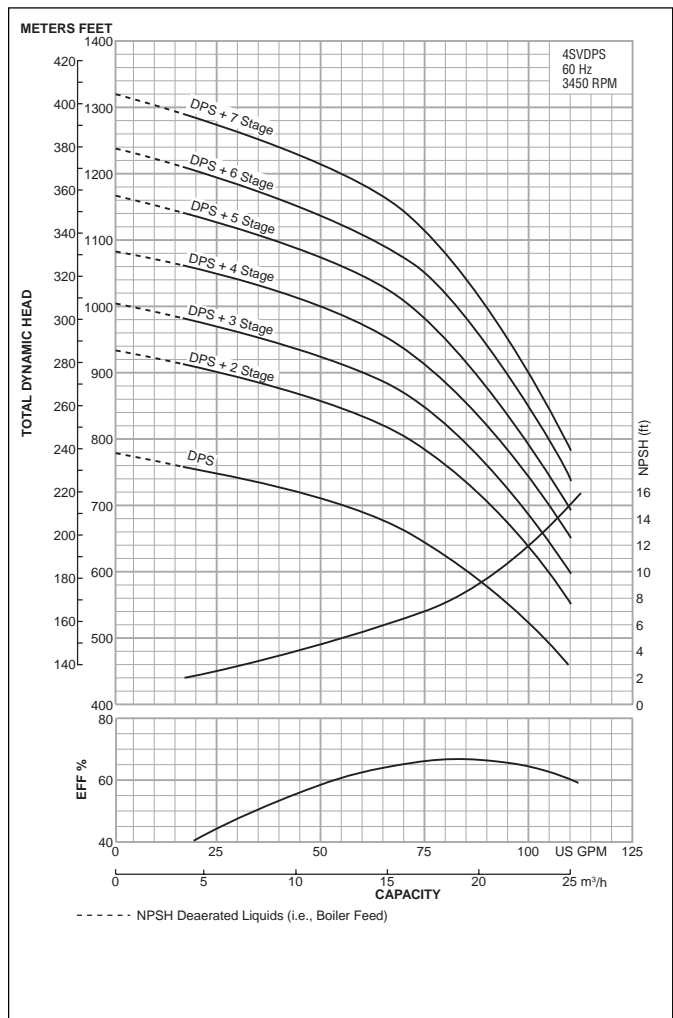

**4SVDPs Motors**

Standard motors supplied by Goulds are NEMA standard TC frame motors open drip proof, or totally enclosed fan cooled enclosures. 60 Hz, 3500 RPM, single phase 2-3 HP (115/208-230 V), 5 HP (208-230 V) and three phase 2 to 10 HP (208-230/460 V), 15 and 20 HP (230/460 V). 4SV horsepower is 2 to 15, DPS horsepower is 20. For other motor options, contact the factory. Above motors are 1.15 S.F.

# 4SVDP5 Dimensions and Weights

(All dimensions are in inches, weights are total unit weight.)

## 4SVD Series

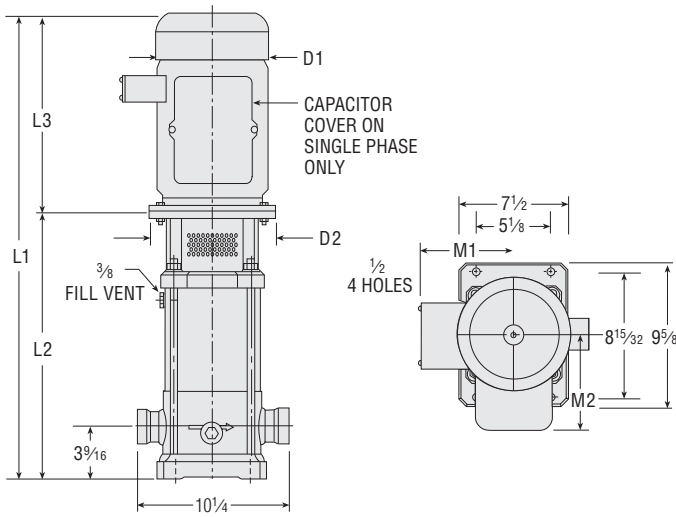

Pump	Stage	Motor		Dimensions (max.)							Wt. (lbs.)	
		Frame	HP	L1	L2	L3	M1	M2	D1	D2	ODP	TEFC
1	2	184TC	5	27 3/4	15 3/4	12	5 7/8	7 1/16	7 7/8	11 13/16	110	120
	30 13/16		15 1/16	120								
	3	184TC	7 1/2	29 1/4	17 1/4	12	5 7/8	-	7 7/8	11 13/16	120	125
	32 9/16		15 1/16	125								
	4	184TC	7 1/2	30 3/4	18 3/4	12	5 7/8	-	7 7/8	11 13/16	120	125
33 13/16	15 1/16		125									
5	213TC (ODP)	10	37	21 1/16	15 1/16	7 3/8	-	9 9/16	11 13/16	165	185	
6 & 7	215TC (ODP)	15	40	24 1/16	15 1/16	7 3/8	-	9 9/16	11 13/16	170	300	
	254TC (TEFC)	15	44 1/16	24 1/16	19 3/8	8 15/16	-	11 1/2	11 13/16	300	300	
2	10	254TC (ODP)	20	45 3/16	28 7/8	16 1/16	8 15/16	-	11 1/2	11 13/16	275	335
	256TC (TEFC)	20	48 7/8	28 7/8	20	9 3/8	-	12 5/16	11 13/16	335	335	

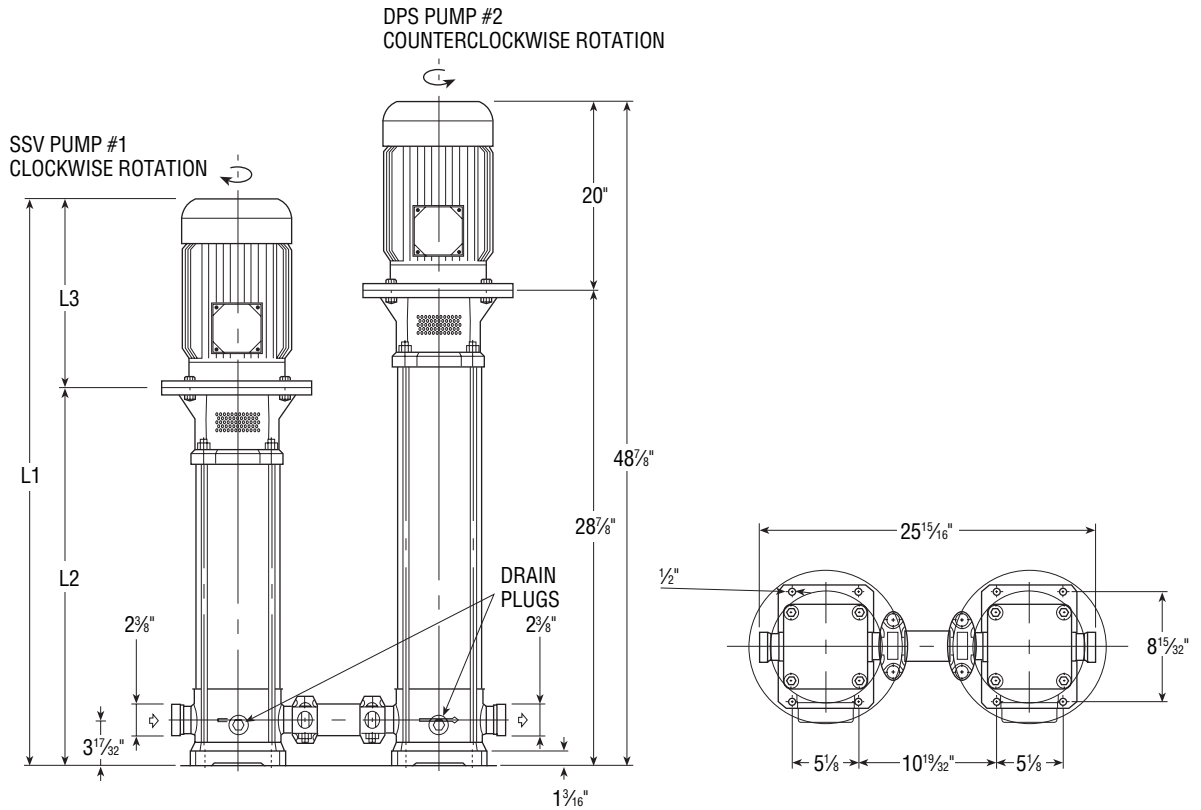

**Base Model: 5SVDPS**  
**General Pump Description**

**5SVDPS Performance Curves**

Construction: 316L stainless steel  
 Capacities: 28–200 gallons per minute (15–45 m<sup>3</sup>/hr)  
 Heads: 320–1270 feet TDH (97–387 meters)  
 Staging: SSV Pump #1 = 2 – 5  
 DPS Pump #2 = 8  
 Minimum flow: 28 GPM  
 Solids handling: Although not recommended, the pump may pass a 3/16" sphere.  
 Piping Connections: Suction and discharge flanges are drilled to 2 1/2", ANSI class 300 pounds.

Component	Materials
Casing O-rings	Viton
Tie-rods and nuts	Zinc-coated steel
Pump shaft	316L SS
Pump casing	316L SS
Intermediate crossover	Cast 316 SS
Top seal housing	316L SS
Inner bowls	316L SS
Diffusers	316L SS
Impellers	316L SS
Shaft spacers	316L SS
Shaft bushing	Ceramic
Shaft sleeve	Tungsten carbide
Seal spring and retainer clip	316L SS

Mechanical seal				
Code No.	Rotary	Stationary	Elastomers	Where Found
0	Carbon	Silicon Carbide	Viton	Stan. on all units
4	Silicon Carbide	Silicon Carbide	Viton	Optional
6	High Temp Carbon	Silicon Carbide	EPR	

Priming and drain plugs	316 SS
NEMA motor adapter	Cast iron
Coupling guards	304 SS
Motor shaft coupling	Cast iron
Pump body/base	Cast 316 SS

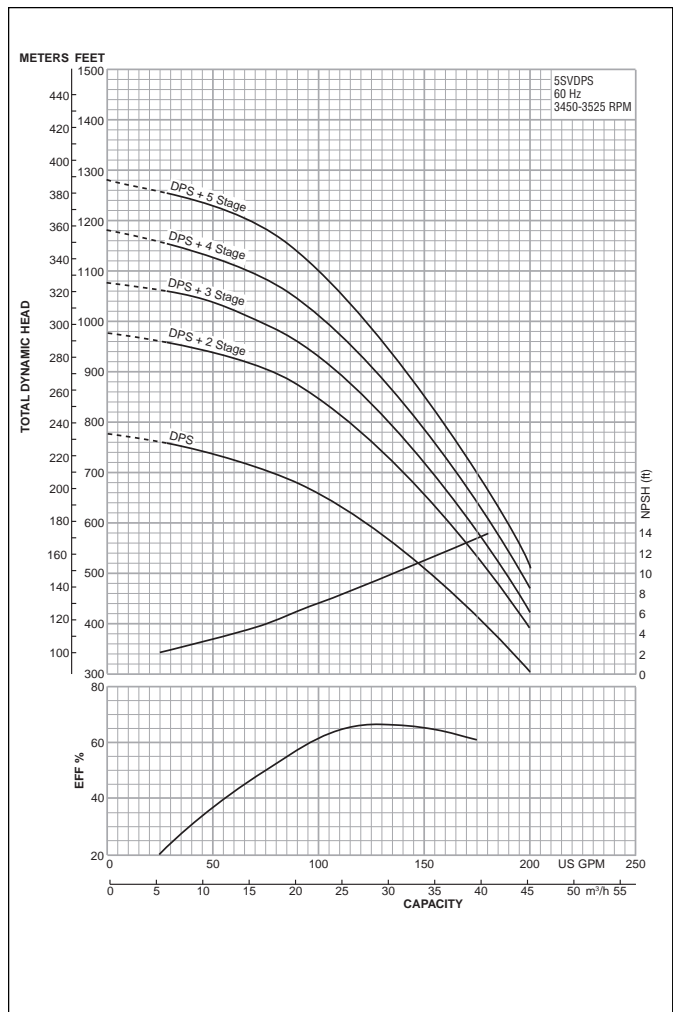

**5SVDPS Motors**

Standard motors supplied by Goulds are NEMA standard TC frame motors open drip proof, or totally enclosed fan cooled enclosures. 60 Hz, 3500 RPM, three phase, 5SV horsepower is 10 HP (208–230/460 V), 15 and 20 HP (230/460 V). 5DPS horsepower is 30 HP (230/460 V). For other motor options, contact the factory. Above motors are 1.15 S.F.

# 5SVDPS Dimensions and Weights

(All dimensions are in inches, weights are total unit weight.)

## 5SVD Series

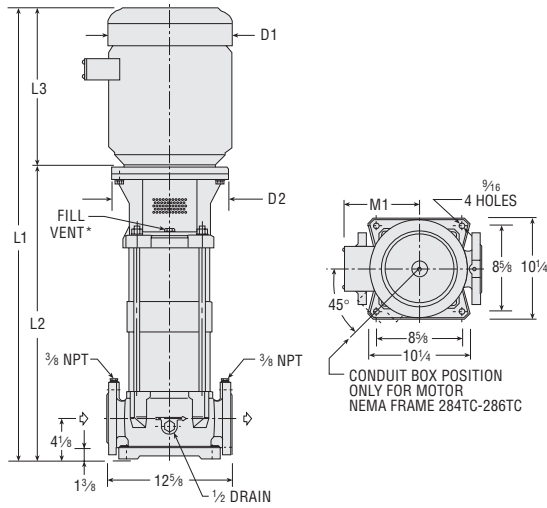

\*VENT 1/2 STEEL

Pump	Stage	Motor		Dimensions (max.)						Wt. (lbs.)	
		Frame	HP	L1	L2	L3	M1	D1	D2	ODP	TEFC
1	2	213TC (ODP)	10	40 3/16	24 3/8	15 1/16	7 3/8	9 9/16	11 13/16	230	
		215TC (TEFC)									255
	3	215TC (ODP)	15	43	27 7/16	15 1/16	7 3/8	9 9/16	11 13/16	240	
		254TC (TEFC)									370
	4	215TC (ODP)	15	43	27 7/16	15 1/16	7 3/8	9 9/16	11 13/16	250	
		254TC (TEFC)									380
5	254TC (ODP)	20	57 1/8	40 1/16	16 7/16	8 15/16	11 1/2	11 13/16	375		
	256TC (TEFC)		60 1/16		20	9 3/8	12 7/16		435		
2	8	284TC (ODP)	30	70 1/8	49 3/4	20 3/8	12 1/4	13 1/4	11 13/16	490	
		286TC (TEFC)		72 1/16		23 1/16	13 3/8	15		610	

DPS PUMP #2  
CLOCKWISE ROTATION

SSV PUMP #1  
CLOCKWISE ROTATION

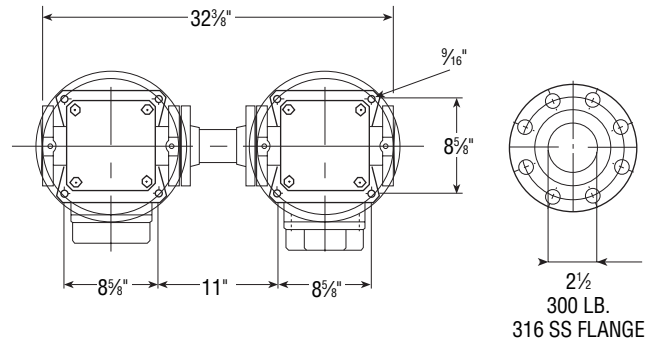
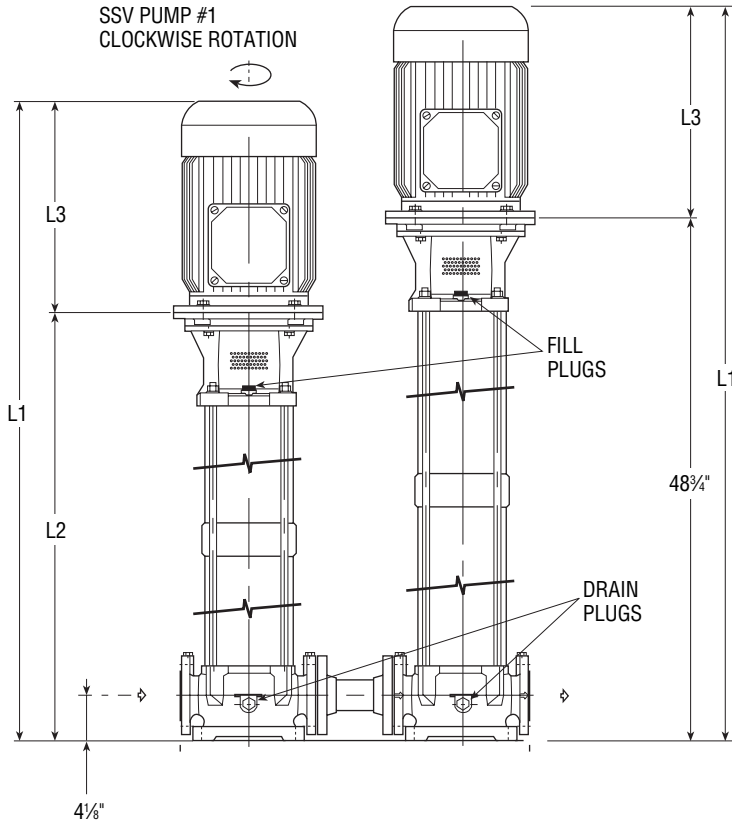

**Base Model: 6SVDPS**  
**General Pump Description**

**6SVDPS Performance Curves**

Construction: 316L stainless steel  
 Capacities: 55–300 gallons per minute (30–68 m<sup>3</sup>/hr)  
 Heads: 440–1230 feet TDH (135–375 meters)  
 Staging: SSV Pump #1 = 2 – 7  
 DPS Pump #2 = 7  
 Minimum flow: 55 GPM  
 Solids Handling: Although not recommended the pump may pass a 3/8" sphere.  
 Piping Connections: Suction and discharge flanges are drilled to 2 1/2", ANSI class 300 pound.

Component	Materials
Casing O-rings	Viton
Tie-rods and nuts	Zinc-coated steel
Pump shaft	316 SS
Pump casing	316L SS
Intermediate crossover	Cast 316 SS
Seal housing	316L SS
Inner bowls	316L SS
Diffusers	316L SS
Impellers	316L SS
Shaft spacers	316L SS
Shaft bushing	Ceramic
Shaft sleeve	Tungsten carbide
Seal spring and retainer clip	316LSS

**Mechanical seal**

Code No.	Rotary	Stationary	Elastomers	Where Found
0	Carbon	Silicon Carbide	Viton	Stan. on all units
4	Silicon Carbide	Silicon Carbide	Viton	Optional
6	High Temp Carbon	Silicon Carbide	EPR	
Prime and drain plugs			316 SS	
NEMA motor adapter			Cast iron	
Coupling guards			304 SS	
Motor shaft coupling			Cast iron	
Pump body/base			Cast 316 SS	

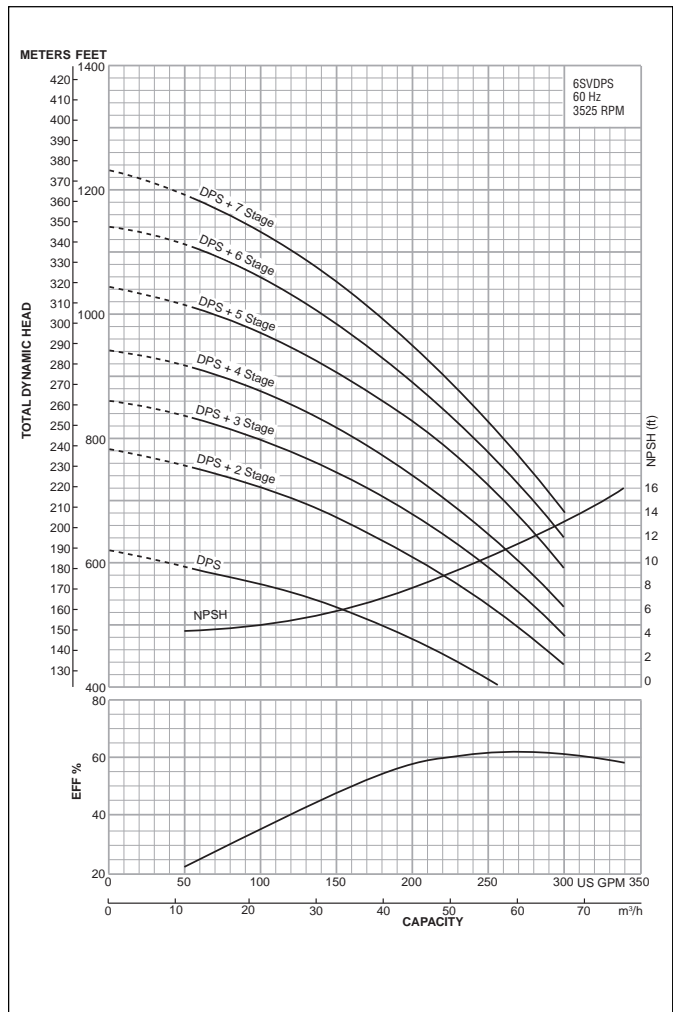

**6SVDPS Motors**

Standard motors supplied by Goulds are NEMA standard TC frame motors open drip proof, or totally enclosed fan cooled enclosures. 60 Hz, 3500 RPM, three phase. 15 to 50 HP (230/460 V). For other motor options, contact the factory. Above motors are 1.15 S.F.

# 6SVDPS Dimensions and Weights

(All dimensions are in inches, weights are total unit weight.)

## 6SVD Series

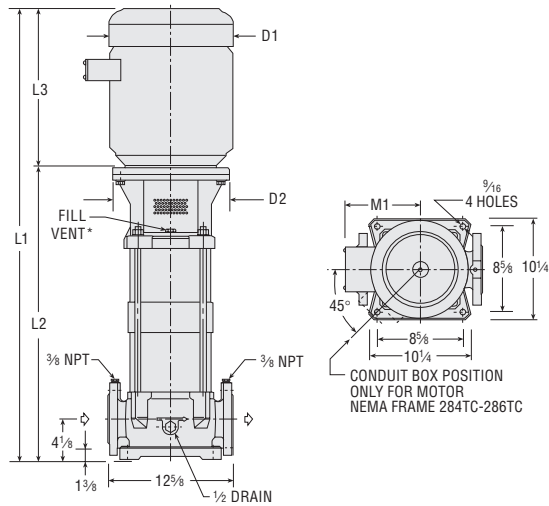

\*VENT 1/2 STEEL

Pump Stage	Motor		Dimensions (max.)							Wt. (lbs.)		
	Frame	HP	L1	L2	L3	M1	D1	D2	ODP	TEFC		
1	2	213TC (ODP)	10	42 1/8	26 9/16	15 9/16	7 3/8	9 9/16	11 13/16	240	265	
		215TC (TEFC)										
	3	215TC (ODP)	15	45	29 7/16	15 9/16	7 3/8	9 9/16	11 13/16	250	385	
		254TC (TEFC)		49 1/16		19 9/16	8 15/16	11 1/2				
	4	254TC (ODP)	20	48 11/16	32 1/4	16 7/16	8 15/16	11 1/2	11 13/16	355	415	
		256TC (TEFC)		52 1/4		20	9 9/16	12 5/16				
	5	256TC (ODP)	25	60 3/8	42 5/8	18	8 5/16	11 1/2	11 13/16	400	580	
		284TC (TEFC)		66 7/16	43 1/4	23 3/16	13 1/8	15				
	6	256TC (ODP)	30	61 1/2	43 1/2	18	12 1/4	13 1/4	11 13/16	490	605	
		284TC (TEFC)		67 7/16	44 1/8	23 3/16	13 1/8	15				
	1 or 2	7	284TC (ODP)	40	65 1/8	46 11/16	19 3/16	12 1/2	13 1/4	11 13/16	503	618
			284TC (TEFC)		69 13/16		23 1/8	13 1/8	15 5/16			

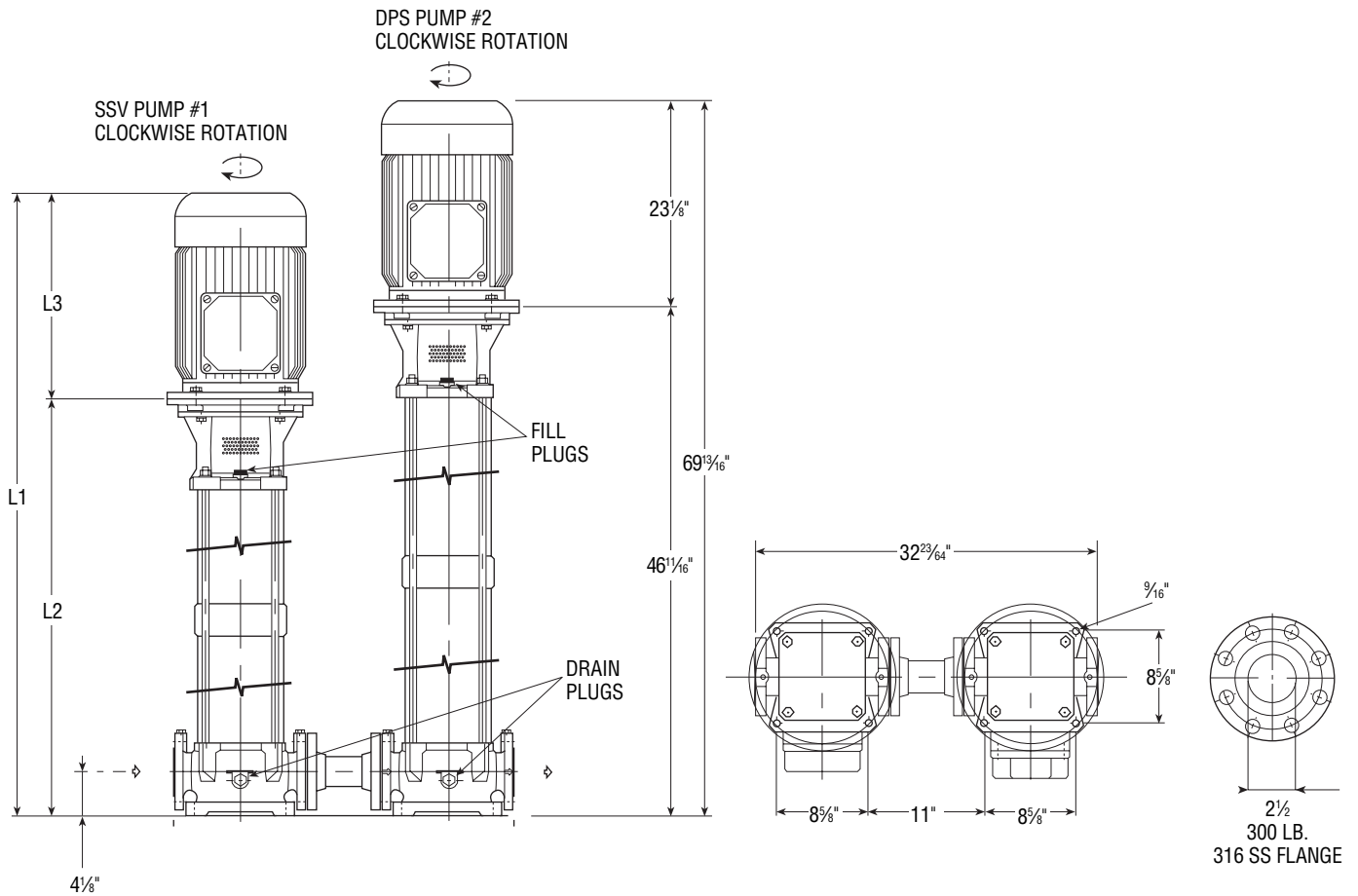

---

**Notes**

---

---

**Notes**

---

